

# MD LOW RANGE PRESSURE SWITCHES

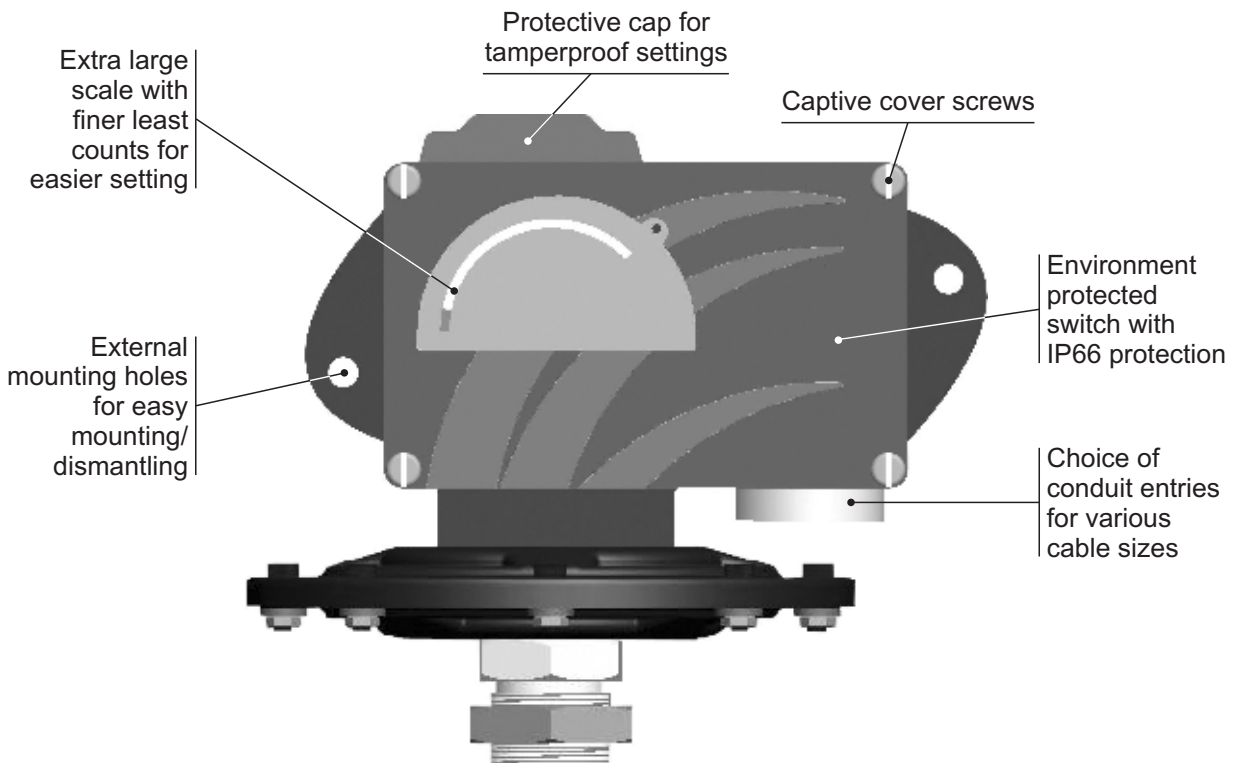
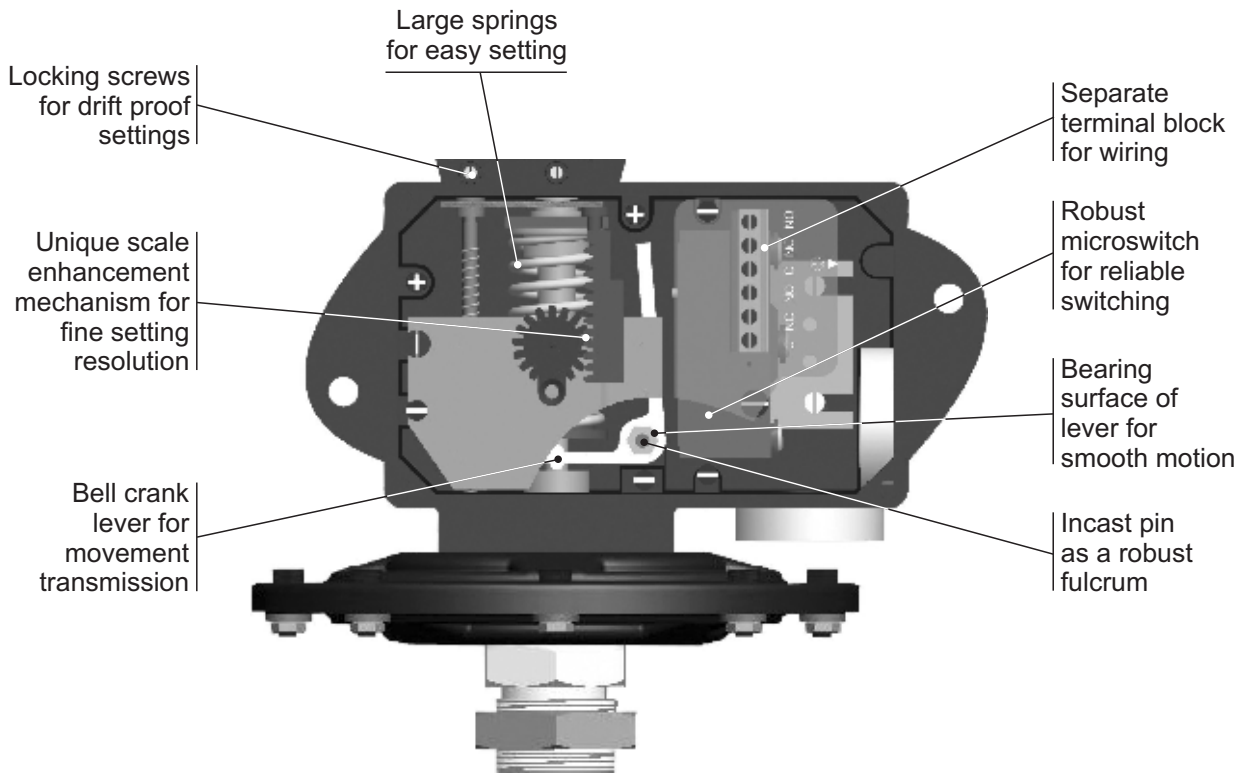

**Approximate Weight :** 1.500 Kg.

**Some Applications :** For clean rooms, air duct systems, ventilation systems, etc.

**Electrical Connection :**

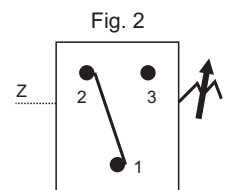

# LOW RANGE PRESSURE SWITCHES MD



## PRESSURE CAPSULE DETAILS

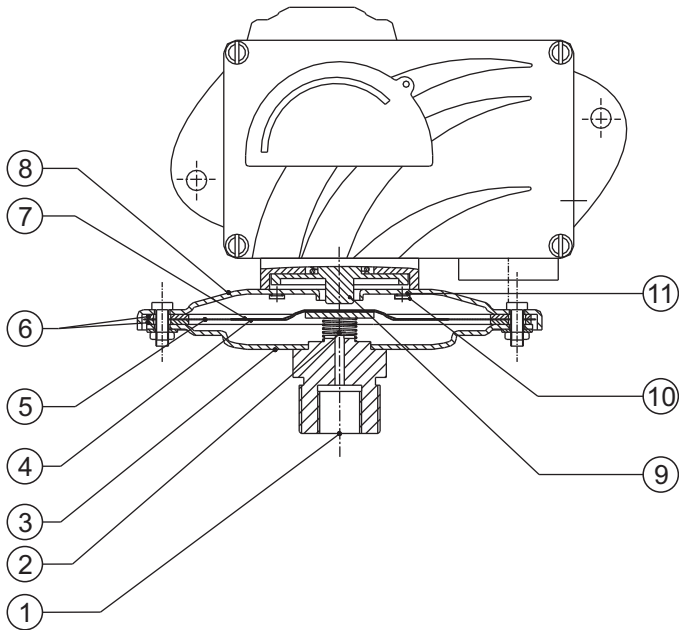

### No. Description

1. *Pressure port (M.S.)\**
2. *Support spring (S.S.)*
3. *Bottom flange (M.S.)*
4. *Support plate (Aluminium)*
5. *Diaphragm (Neoprene)*
6. *Gasket (Nitrile)*
7. *Top plate (Aluminium)*
8. *Top flange (M.S.)*
9. *Plunger*
10. *Top flange screw (M.S.)*
11. *Sealing 'O' ring (Nitrile)*

\*Pressure port is brazed with flange

Note : *wetted parts* are mentioned in italics.

## INSTALLATION DRAWING

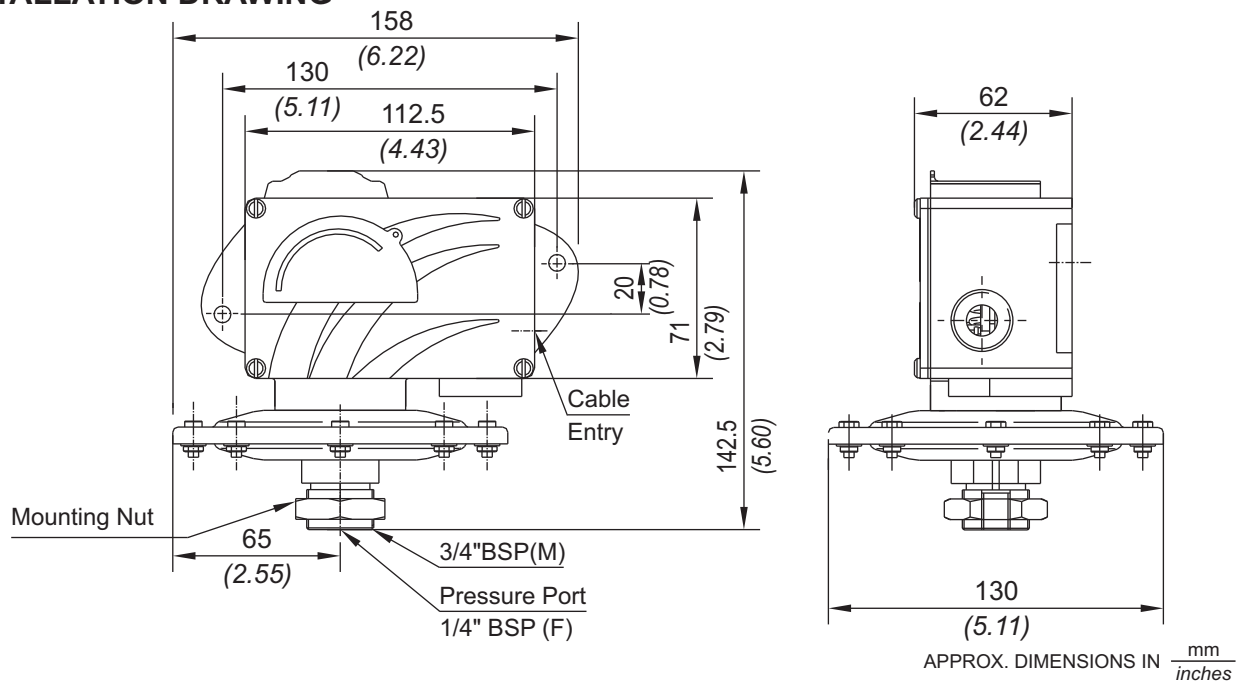

# MD LOW RANGE PRESSURE SWITCHES

## RANGE SELECTION TABLE

Range Code	Range mbar ("wc)	Differential* mbar ("wc)	Maximum Working Pressure bar (psi)
		Approximate Maximum for "A1" microswitch	
L02	1.5 - 15.0 (0.602 - 6.021)	3 (1.204)	2 (29.00)
L03	5.0 - 25.0 (2.007 - 10.037)	5 (2.007)	2 (29.00)
L05	10.0 - 50.0 (4.015 - 20.073)	5 (2.007)	2 (29.00)
L10	10.0 - 100.0 (4.015 - 40.146)	10 (4.015)	2 (29.00)
L15	10.0 - 150.0 (4.015 - 60.22)	10 (4.015)	2 (29.00)
L25	20.0 - 250.0 (8.029 - 100.36)	15 (6.021)	2 (29.00)
L35	50.0 - 350.0 (20.073 - 140.52)	25 (10.036)	2 (29.00)

\*Minimum differential increases with setpoint (Graphs available on request)

**\* Note :**

Microswitches A2 through A9 can be supplied in some ranges and differentials will vary with microswitch used. Please contact sales office for details. Please check availability of adjustable differential with sales office.

## HOW TO ORDER INDUSTRIAL LOW RANGE PRESSURE SWITCHES

Group 1	Group 2	Group 3	Group 4	Group 5	Group 6	Group 7	Group 8
Non standard allocation	Model	Cable Entry Size	Switch Type	Range Code (values in mbar)	Microswitch Type	Pressure Port Material / Size	Diaphragm
<input type="checkbox"/> Reserved for non-standard options not covered in catalogue. Will be given by manufacturer, only after agreement of supply details with customer.	<b>MD</b> = Industrial pressure switch with diecast Aluminium enclosure to IP66 as per IS2147	<b>1</b> = 1/2" NPT threads <b>2</b> = 3/4" NPT threads <b>3</b> = M20 X 1.5 threads	<b>PF1</b> = pressure switch, fixed differential without scale <b>PF2</b> = pressure switch, fixed differential with scale in mbar <b>PF3</b> = pressure switch, fixed differential with scale in "wc <b>PA1</b> = pressure switch, adjustable differential without scale <b>PA2</b> = pressure switch, adjustable differential with scale in mbar <b>PA3</b> = pressure switch, adjustable differential with scale in "wc *Available with A9 (in group 6) only	<b>L02</b> = (1.5 - 15) <b>L03</b> = (5 - 25) <b>L05</b> = (10 - 50) <b>L10</b> = (10 - 100) <b>L15</b> = (10 - 150) <b>L25</b> = (20 - 250) <b>L35</b> = (50 - 350)	<b>A1</b> = General purpose microswitch rated at 15 A; 250 VAC <b>A2</b> = Hermetically sealed for corrosive environments <b>A3</b> = gold plated contacts for low voltage applications <b>A4</b> = DPDT configuration <b>A5</b> = for high DC ratings <b>A7</b> = 2SPDT switching elements <b>A9</b> = General purpose microswitch rated at 5 A; 250 VAC  Please refer page no. 230 for more microswitch options * Please refer note under Range Selection Table	<b>M1</b> = M.S. powder coated / 1/4" BSP(F) <b>M2</b> = M.S. powder coated / 1/4" NPT(F) <b>S1</b> = SS316 / 1/4" BSP(F) <b>S2</b> = SS316 / 1/4" NPT(F)	<b>0</b> = Neoprene <b>1</b> = Teflon <b>2</b> = SS316L

eg. A low range weatherproof switch, with 1/2" NPT cable entry in aluminium housing as 1SPDT pressure switch, fixed differential without scale, having 5 mbar to 25 mbar pressure range, with 15 Amp. microswitch, SS316 pressure housing with 1/4" BSP port size & neoprene diaphragm shall be specified by

Group 1	Group 2	Group 3	Group 4	Group 5	Group 6	Group 7	Group 8
<input type="checkbox"/>	MD	1	PF1	L03	A1	S1	0

Please specify full model number to avoid ambiguity.